

# CONVERSION TO WIRELESS WALL CONTROLLER

The following instructions are for converting an Essence® fan originally set up for a wired wall controller over to a wireless wall controller. Consult the complete installation guide for all other aspects of fan installation.

- ⚠ **WARNING:** Make sure power is disconnected at the fuse/breaker distribution panel before installing or servicing the fan or wall controller.
- ⚠ **CAUTION:** Avoid touching the fan's electronics.
- ⚠ **CAUTION:** Do NOT install the wireless wall controller outdoors or in a location where it may come into contact with water.
- ⚠ **CAUTION:** The installation of the wireless wall controller must be in accordance with all local codes.
- ⚠ **CAUTION:** The Big Ass Fans product warranty will not cover damage or failure caused by improper installation.

## Parts Included

*Note: Big Ass Fans recommends installing the wireless wall controller in a plastic junction box. A junction box is not supplied with this kit.*

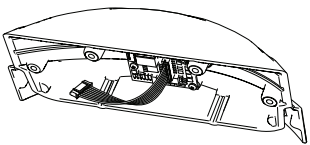

Electronics Access Cover



Wireless Wall Controller

## Installing the Electronics Access Cover

### 1. Remove original cover

Loosen the screws securing the cover and remove it. Keep the screws for use in step 3.

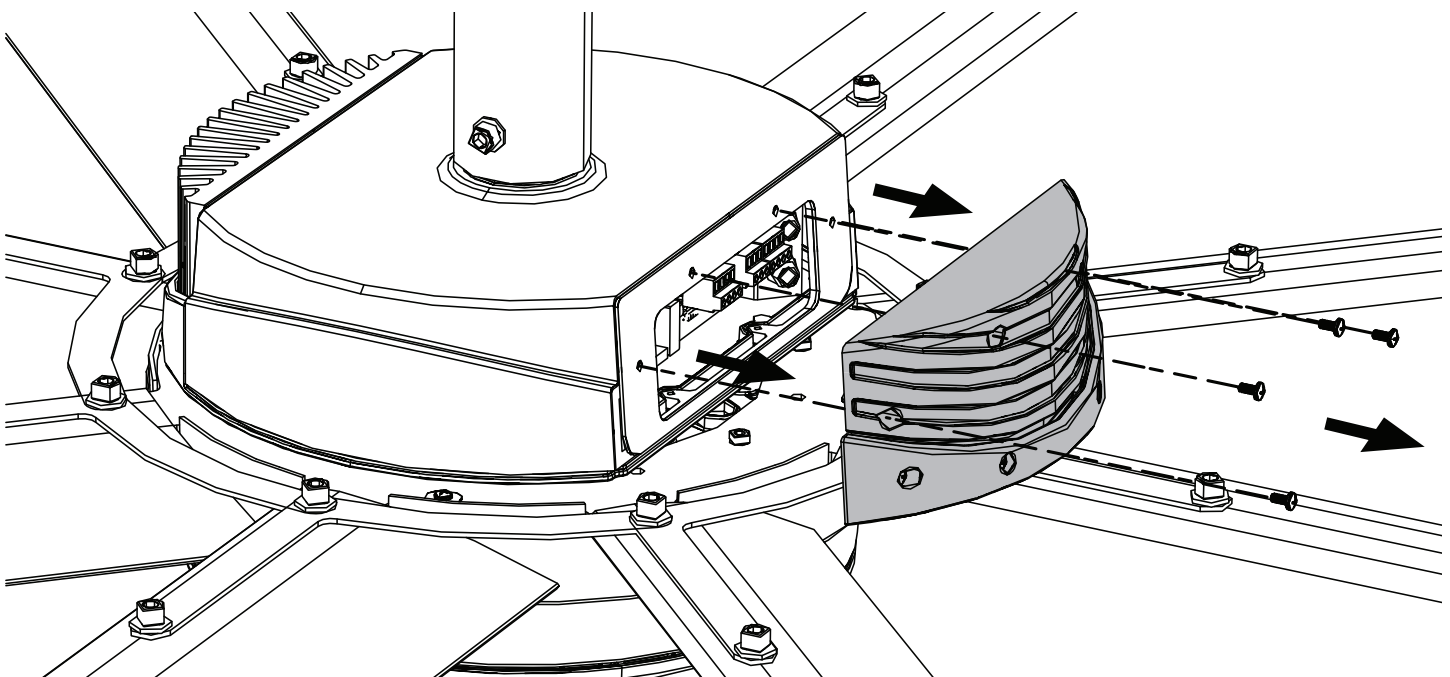

## 2. Connect wiring assembly

Plug the wiring assembly from the new electronics access cover into the receptacle labeled “RF” on the fan electronics board.

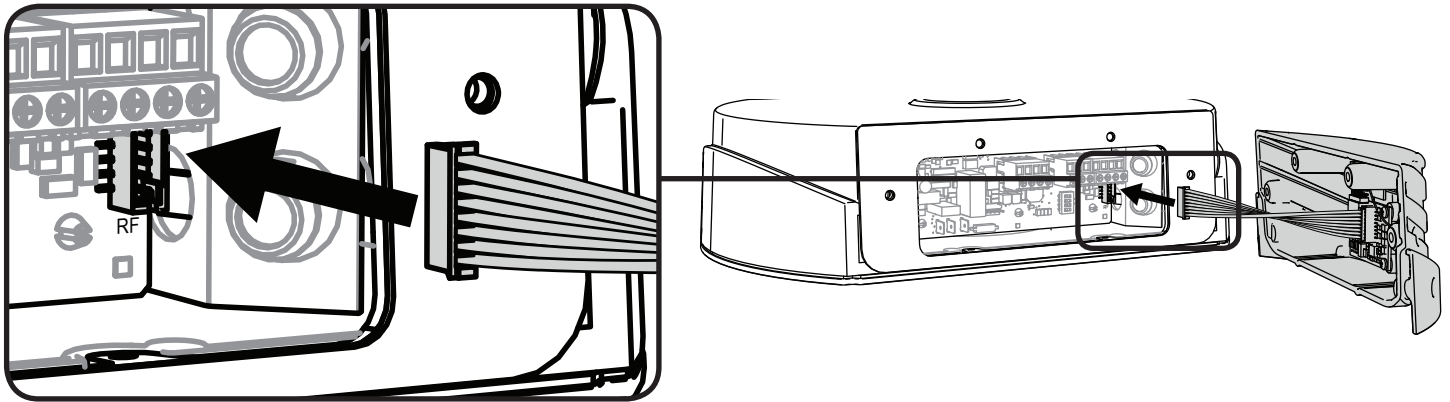

## 3. Secure new electronics access cover

Secure the new cover on the fan using the screws from step 1.

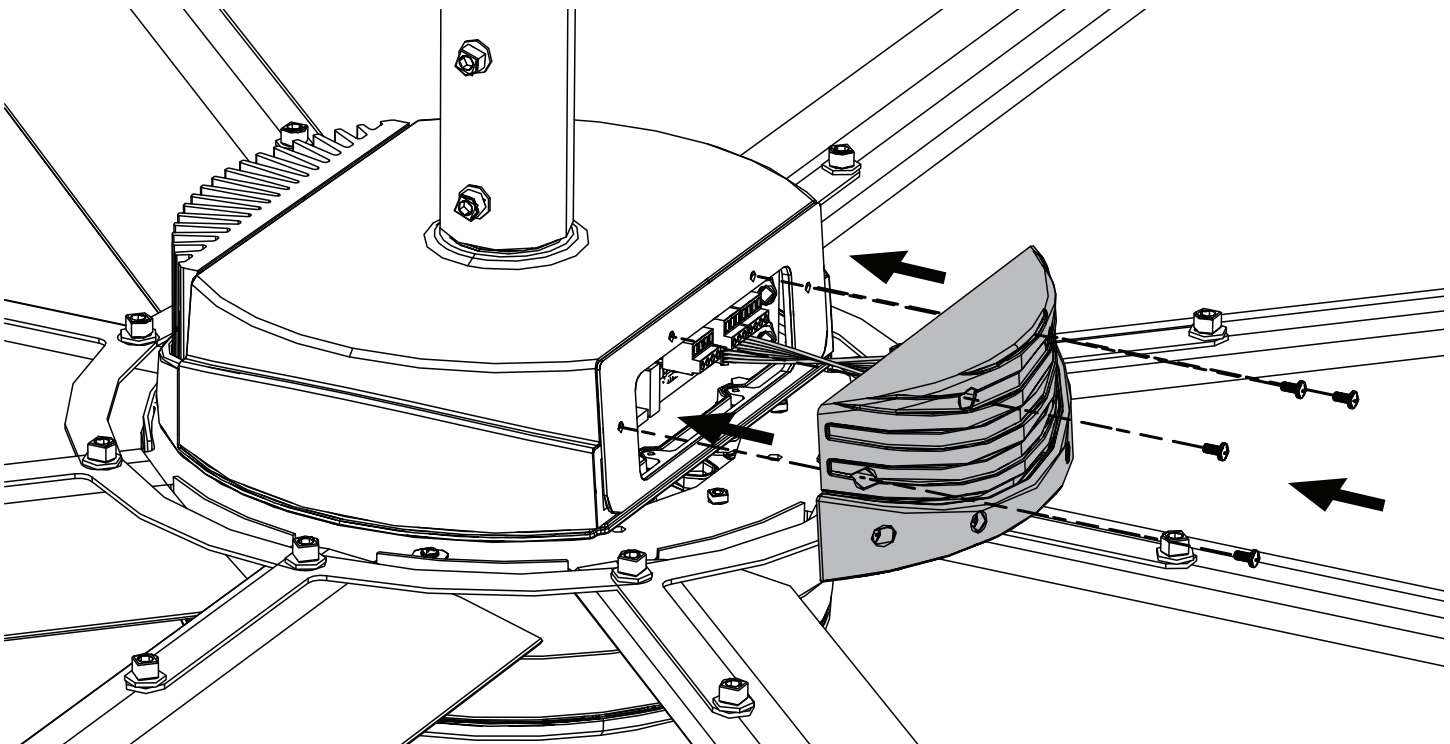

# Installing the Wireless Wall Controller

**⚠ WARNING:** To reduce the risk of electric shock, wiring should be performed by a qualified electrician! Incorrect assembly can cause electric shock or damage the motor and the controller! Hazard of electrical shock!

**⚠ WARNING:** Ensure power is disconnected at the fuse/breaker distribution panel before installing or servicing the wireless wall controller and fan!

**⚠ CAUTION:** Do NOT install the wireless wall controller outdoors or in a location where it may come into contact with water.

**⚠ CAUTION:** The installation of the wireless wall controller must be in accordance with all local codes.

Mount the wireless wall controller on a flat surface that is readily accessible, free from vibration, and where there is adequate distance from foreign objects or moving equipment. To optimize communication between the wireless wall controller and the fan(s), Big Ass Fans recommends installing the wireless wall controller in a plastic junction box. *Note: The controller wall plate is customer-supplied. Big Ass Fans recommends using a Decora® wall plate. Other brands may not be compatible. The junction box and wire nuts are also customer-supplied.*

The wireless wall controller can be used to control a single fan or up to three (3) linked fans. If installing linked fans, the first fan must be located within 50 ft (15.2 m) of the wall controller. Successive fans must be within 50 ft (15.2 m) of each other with no physical obstructions between fans.

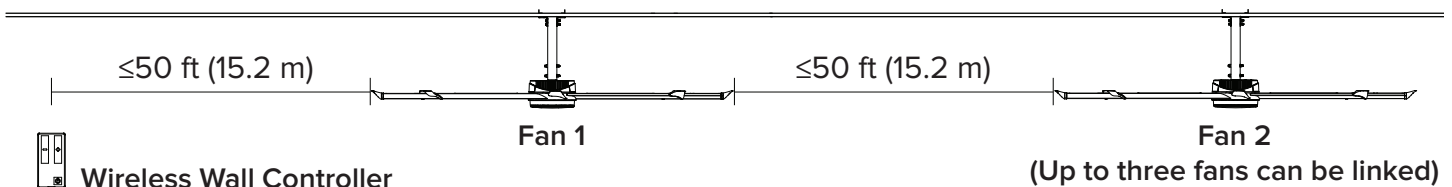

## 1a. Set the wall controller address (single fans)

The wireless wall controller is shipped with a default address for controlling a single fan. If installing multiple wall controllers each controlling a single fan, you must set each controller to a different address to prevent the controllers from interfering with each other. There are 32 available controller addresses (two sets of 16) to prevent interference between multiple wall controllers.

### To set the wall controller's DIP switch:

1. Remove the rubber covering from the back of the wall controller.
2. Locate the DIP switch and rotary switch. Refer to the illustration on the following page.
3. Set the DIP switch positions. Switch 1 can be either on or off, allowing access to the first or second set of rotary switch settings. Switch 2 can also be on or off. Move switch 3 to the ON position. Move switch 4 to the OFF position. Refer to the illustration on the following page.

**To set the rotary switch address,** use a small screwdriver or similar tool to turn the rotary switch to an available channel. For example, in the illustrations on the following page, the first DIP switch (1) is on, which means that the first set of 16 addresses is active. The rotary switch is set to channel 2.

To access the first set of 16 addresses, set the first DIP switch (1) to the ON position and adjust the rotary switch. To access the second set of 16 addresses, set the first DIP switch (1) to the OFF position and adjust the rotary switch.

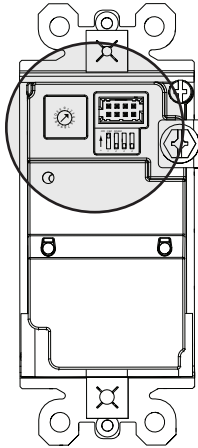

Wall Controller DIP Switch (Single Fan Setting)

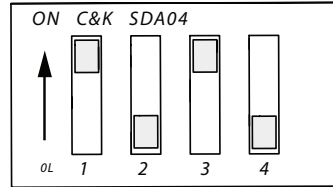

Rotary Switch

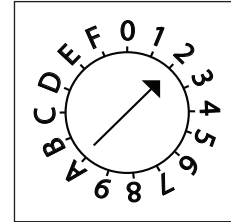

### 1b. Set the wall controller address (linked fans)

Link up to three fans to a single controller to simultaneously control airflow. There are 32 available controller addresses (two sets of 16) to prevent interference between multiple wall controllers.

To set the wall controller's DIP switch:

1. Remove the rubber covering from the back of the wall controller.
2. Locate the DIP switch and rotary switch. Refer to the illustration below.
3. Set the DIP switch positions. Switch 1 can be either on or off, allowing access to the first or second set of rotary switch settings. Switch 2 can also be on or off. Move switch 3 and switch 4 to the ON position. Refer to the illustration below.

To set the rotary switch address, use a small screwdriver or similar tool to turn the rotary switch to an available channel. For example, in the illustrations below, the first DIP switch (1) is on, which means that the first set of 16 addresses is active. The rotary switch is set to channel 2.

To access the first set of 16 addresses, set the first DIP switch (1) to the ON position and adjust the rotary switch. To access the second set of 16 addresses, set the first DIP switch (1) to the OFF position and adjust the rotary switch.

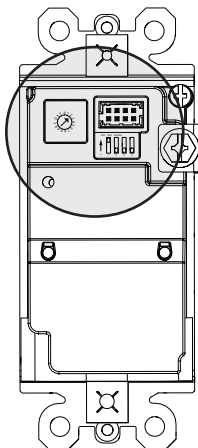

Wall Controller DIP Switch (Multi-Fan Setting)

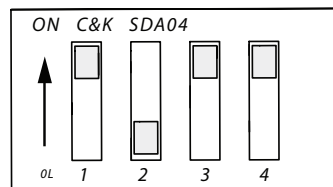

Rotary Switch

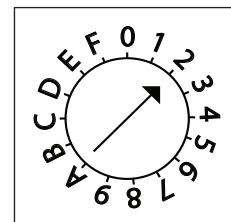

## 2. Locate fan RF board

**⚠ CAUTION: Do not touch the fan's electronics unless necessary!**

Remove power from the fan(s). Remove the electronics cover from the fan(s) as shown. The electronics cover is attached to the fan with four (4) screws. **The RF board is located inside the electronics cover.** Refer to the illustrations below.

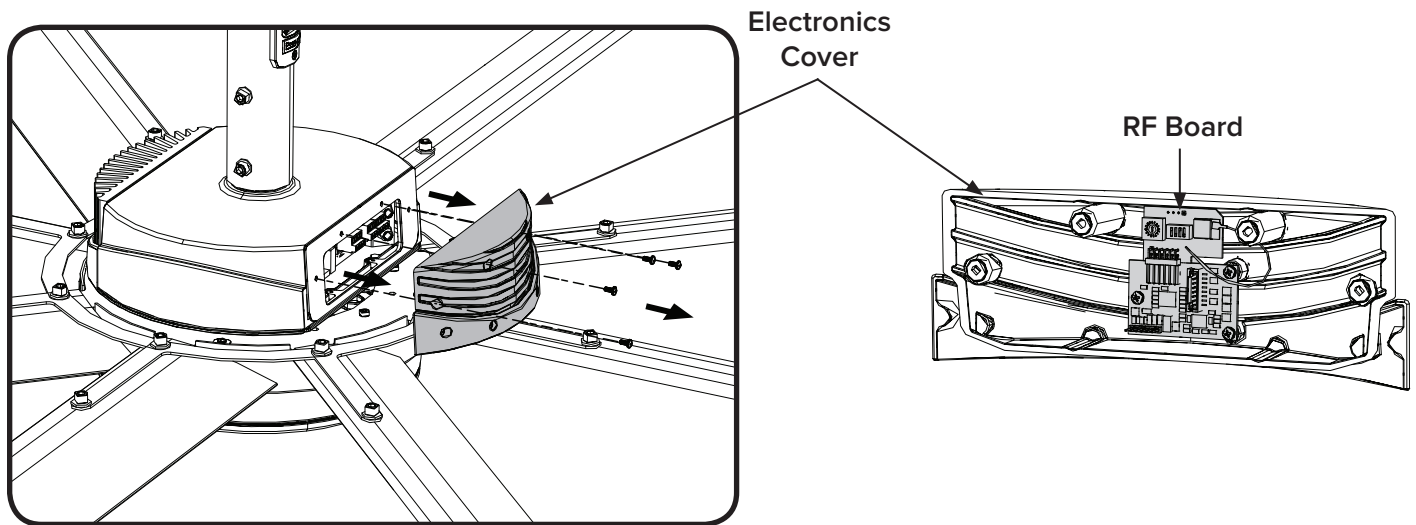

### 3a. Set the RF board address (single fans)

To set the RF board address:

1. Locate the DIP switch and rotary switch on the fan's RF board. Refer to the illustration below.
2. Set the DIP switch positions. Set switch 1 to match switch 1 on the wall controller. *Switch 1 must be set to the same position as switch 1 on the wall controller to ensure the correct set of rotary switch settings is available.* Switch 2 can be on or off. Move switch 3 and switch 4 to the OFF position. Refer to the illustration below.
3. Set the rotary switch address to match the rotary switch address on the wall controller. Refer to the illustration below.
4. When you are finished, reattach the fan's electronics cover.

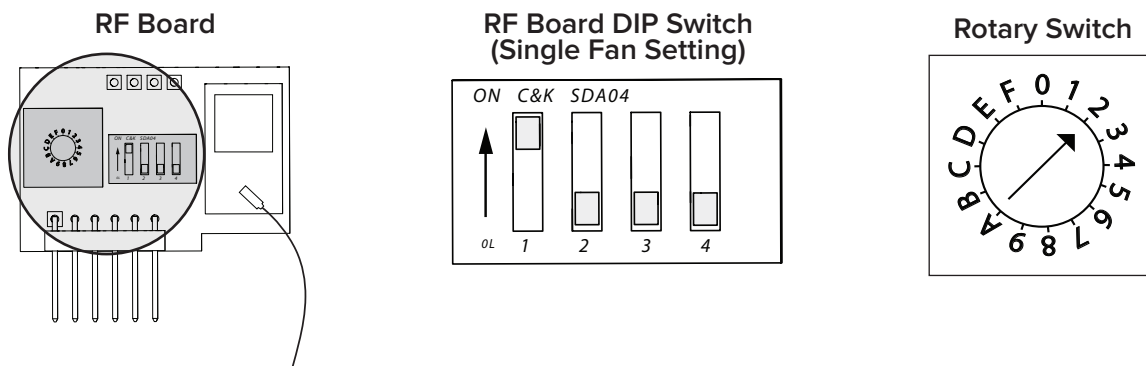

### 3b. Set the RF board address (linked fans)

To set the RF board address:

1. Locate the DIP switch and rotary switch on the first fan's RF board. Refer to the illustration below.
2. Set the DIP switch positions. Set switch 1 to match switch 1 on the wall controller. *Switch 1 must be set to the same position as switch 1 on the wall controller to ensure the correct set of rotary switch settings is available.* Switch 2 can be on or off. Move switch 3 and switch 4 to the ON position. Refer to the illustration below.
3. Set the rotary switch address to match the rotary switch address on the wall controller. Refer to the illustration below.
4. Set each linked fan's RF board to the identical DIP switch positions and rotary switch address.
5. When you are finished, reattach each fan's electronics cover.

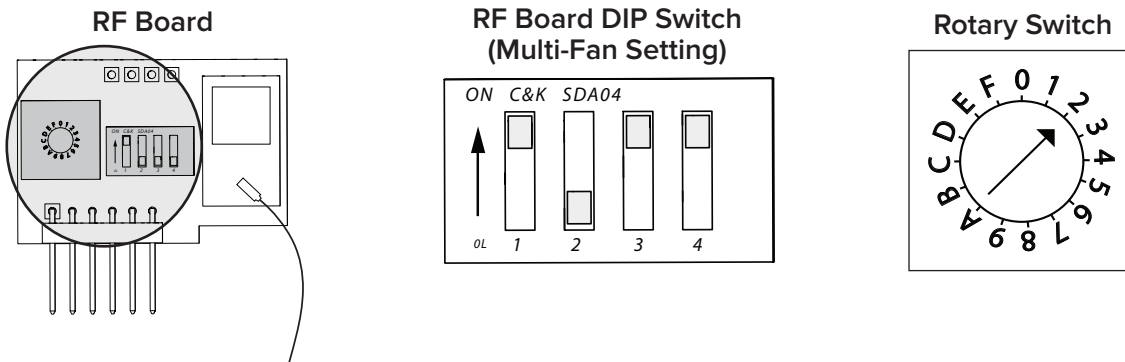

### 4. Wire the wall controller and fan

**⚠ WARNING: Ensure power is disconnected at the fuse/breaker distribution panel before wiring the wall controller and fan!**

Wire the wall controller and fan as shown in the diagrams below. If switch leg wiring is not possible, secure the red wire on the wall controller with a customer-supplied wire nut. Refer to the wiring diagram on the following page.

*Note: A junction box is not supplied. Big Ass Fans recommends installing the wireless wall controller in a plastic junction box.*

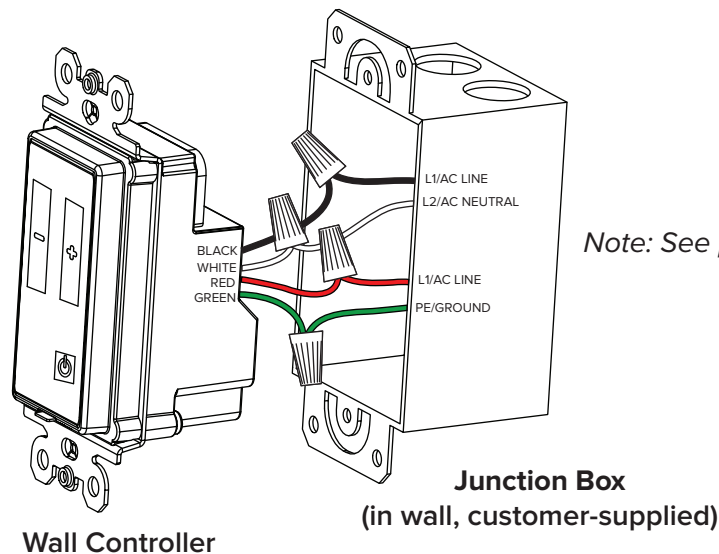

*Note: See page 9 for wire colors.*

## Wiring diagram (with switch leg)

**⚠ WARNING: Ensure power is disconnected at the fuse/breaker distribution panel before wiring the wall controller and fan!**

Switch leg is recommended by Big Ass Fans. If switch leg wiring is not possible, secure the end of the red wire on the wall controller with a customer-supplied wire nut. Refer to the wiring diagram on the following page.

### Power Supply

See page 9 for specifications and wire colors.

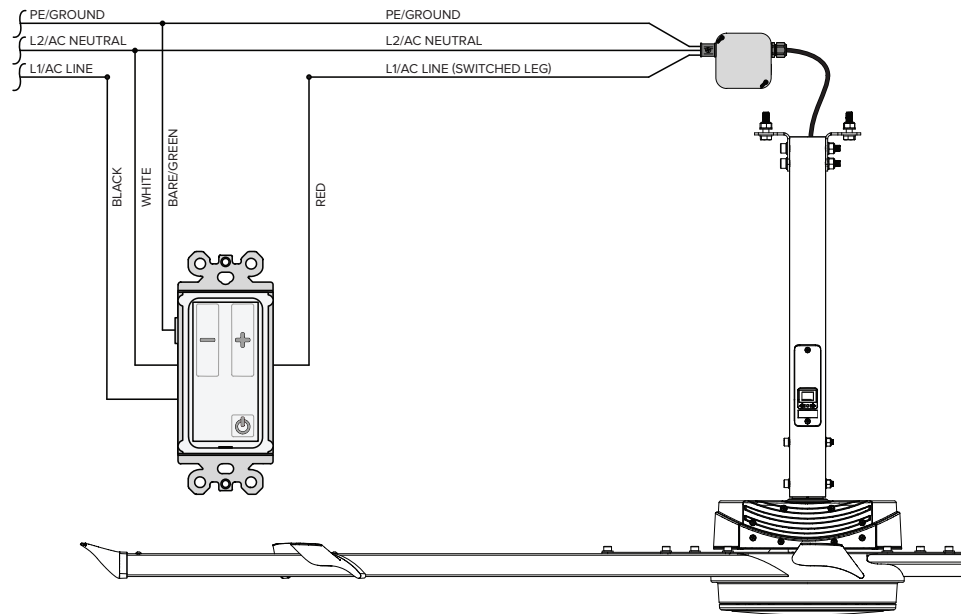

## Wiring diagram (switch leg wiring not available)

**⚠ WARNING: Ensure power is disconnected at the fuse/breaker distribution panel before wiring the wall controller and fan!**

If switch leg wiring is not possible, secure the end of the red wire on the wall controller with a customer-supplied wire nut as shown.

### Power Supply

See page 9 for specifications and wire colors.

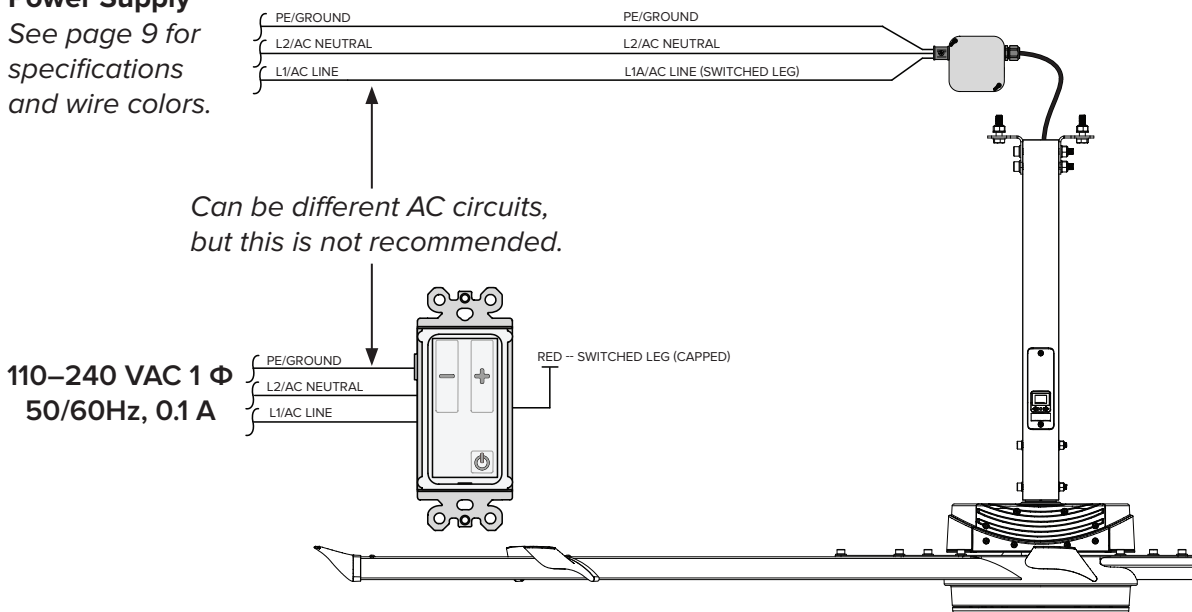

## 5. Mount the wall controller

Mount the wall controller with the two (2) provided 6-32 x 7/8" screws (a) in a location within 50 ft (15.2 m) of the fan (or the first fan if you are installing multiple linked fans). Do not overtighten the screws. Install the customer-supplied wall plate using the screws provided with the wall plate (b). *Note: Big Ass Fans recommends using a Decora® wall plate. Other brands may not be compatible.*

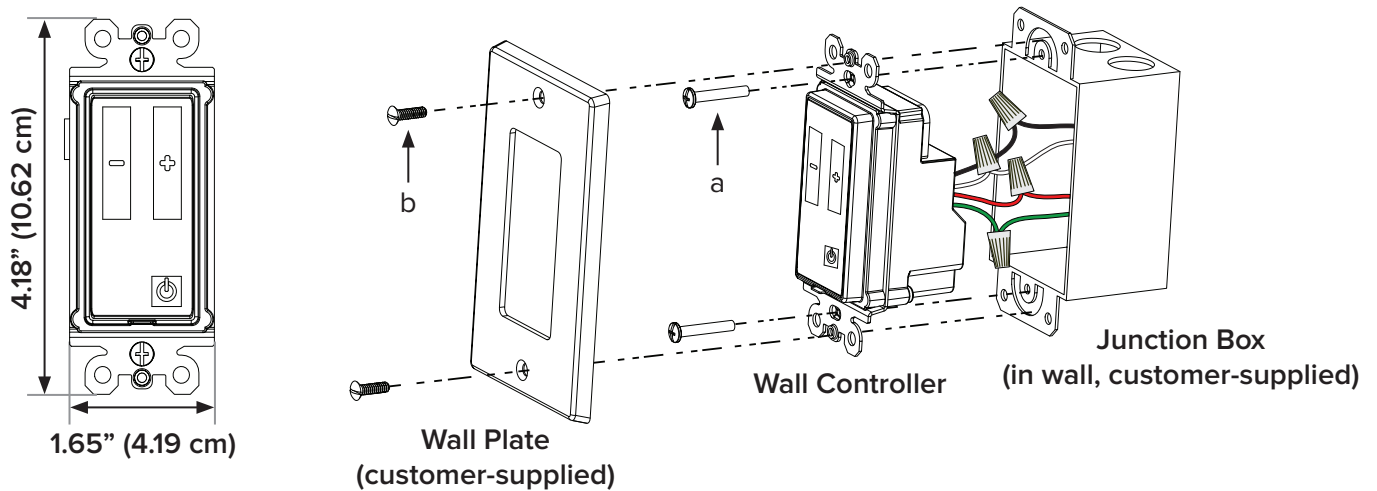

## 6. Test the fan(s)

Apply AC power, and then turn on the fan(s) using the wall controller to test the DIP switch address. If the wall controller does not operate the fan(s) due to interference with other radio frequency devices, select a different address on the wall controller, and then set the matching address on the fan RF board(s). Retest. Repeat until an appropriate address is determined.

For troubleshooting the controller, consult the complete Essence Installation Guide available at [bigassfans.com/support](http://bigassfans.com/support)



# Power Requirements

Essence® is shipped with either a 110–125 VAC motor or a 200–240 VAC motor. The fan's voltage is marked on the fan packaging and on the label on top of the main fan unit. **The voltage cannot be changed during installation.** Ensure your fan is the correct voltage prior to beginning installation.

Fan Diameter	Input Power	Min Required Supply Circuit Size	Rated current
8 ft (2.44 m)	110–125 VAC, 50/60 Hz, 1 $\Phi$	10 A	5.7 A
	200–240 VAC, 50/60 Hz, 1 $\Phi$		3.6 A
10 ft (3.05 m)	110–125 VAC, 50/60 Hz, 1 $\Phi$	10 A	5.3 A
	200–240 VAC, 50/60 Hz, 1 $\Phi$		3.4 A
12 ft (3.66 m)	110–125 VAC, 50/60 Hz, 1 $\Phi$	10 A	4.3 A
	200–240 VAC, 50/60 Hz, 1 $\Phi$		2.7 A
14 ft (4.27 m)	110–125 VAC, 50/60 Hz, 1 $\Phi$	10 A	3.8 A
	200–240 VAC, 50/60 Hz, 1 $\Phi$		2.4 A

## Wire Color Chart

	AC Line (L1)	AC Line/Neutral (L2/N)	Earth/PE
North America 100–120 V System	Black	White	Green or Bare Copper
North America 208–240 V System	Black, Red, or Blue	Red, Blue, or Black	
Australia	Brown or Red	Black or Light Blue	Green with Yellow Tracer
All Other Regions	Brown	Blue	







ESS-INST-53-MUL-01  
REV. C  
09/06/19